

Analogue DC Servo amplifier

05/100 10/100 and 20/100



Installation Manual



TRM International Ltd Ltd. 86 Moss Road, Southport, Lancashire. PR8 4JQ

Web: <http://www.trminternational.com> email: sales@trminternational.com

Telephone: +44 (0)1704 563777 Facsimile: +44 (0)1704 565219

MAIN FEATURES:

- 24 to 100 volts input range
- Adjustable current limit
- Adjustable null offset
- Adjustable gain control
- Enable and error indicator
- Current mode operation
- Enable high or enable low
- +/- 10 volts command signal

Description

The TRM 10/100 and 20/100 Analogue Amplifiers are the latest products designed by TRM to complete the range of Motion Control products to provide a whole and reliable solution to our customers. These amplifiers are designed to drive brushed DC motors at a high switching frequency in current mode. Three LED's indicate operating status and a single power supply is required. Both models are protected against over-current, over-voltage, over-heating, and short circuits. Gain, current limit and offset can be adjusted easily using potentiometers.

SPECIFICATIONS:

Power Stage Specifications	5/100 Amplifier	10/100 Amplifier	20/100 Amplifier
DC SUPPLY VOLTAGE	24-100 volts	24-100 volts	24-100 volts
PEAK CURRENT	5 A	10 A	20 A
MAXIMUM CONTINUOUS CURRENT	5 A	10 A	20 A
MINIMUM LOAD INDUCTANCE	200 uH	200 uH	200 uH
SWITCHING FREQUENCY	33 Khz	33 Khz	33 Khz
HEATSINK TEMPERATURE RANGE	0 - 70 C	0 - 70 C	0 - 70 C
OVER VOLTAGE PROTECTION	106 V	106 V	106 V
BANDWIDTH	Greater than 1 Khz	Greater than 1 Khz	Greater than 1 Khz

TRM International Ltd Ltd. 86 Moss Road, Southport, Lancashire. PR8 4JQ

Web: <http://www.trminternational.com> email: sales@trminternational.com

Telephone: +44 (0)1704 563777 Facsimile: +44 (0)1704 565219

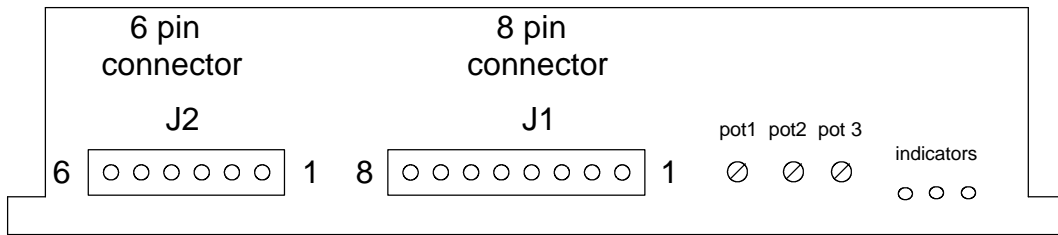

Analogue amplifier J1 connector

PIN NUMBER	NAME	DESCRIPTION
1	Motor command + (input)	Differential analogue input +/- 10 V
2	Motor command - (input)	
3	Error output	It is a positive voltage when there is an error
4	Enable -	Digital input to enable the amplifier with 0 volts (ground)
5	Enable +	Digital input to enable the amplifier with + 5 volts
6	Current output	Analogue output proportional to the current, from 0 to 2.35 V
7	+ 5 volts output	Internal 5 volts supply
8	0 Volts output	Internal 0 Volts (ground)

Analogue amplifier J2 connector

PIN NUMBER	NAME	DESCRIPTION
1	0 Volts	Power Ground
2	0 Volts	Spare power ground to link with another amplifier
3	+Vcc Volts	DC voltage input
4	+Vcc Volts	Spare DC voltage to link with another amplifier
5	Motor output (to the motor)	Motor connection
6	Motor output (to the motor)	Motor connection

Potentiometers

POTENTIOMETER	DESCRIPTION	TURNING CLOCKWISE
POT 1	Adjust the gain for the input	Increases reference input gain
POT 2	Offset, adjust the point 0 (no movement)	Moves 0 point
POT 3	Adjust the current limit	Increases current limit

Connections diagram

Enable High

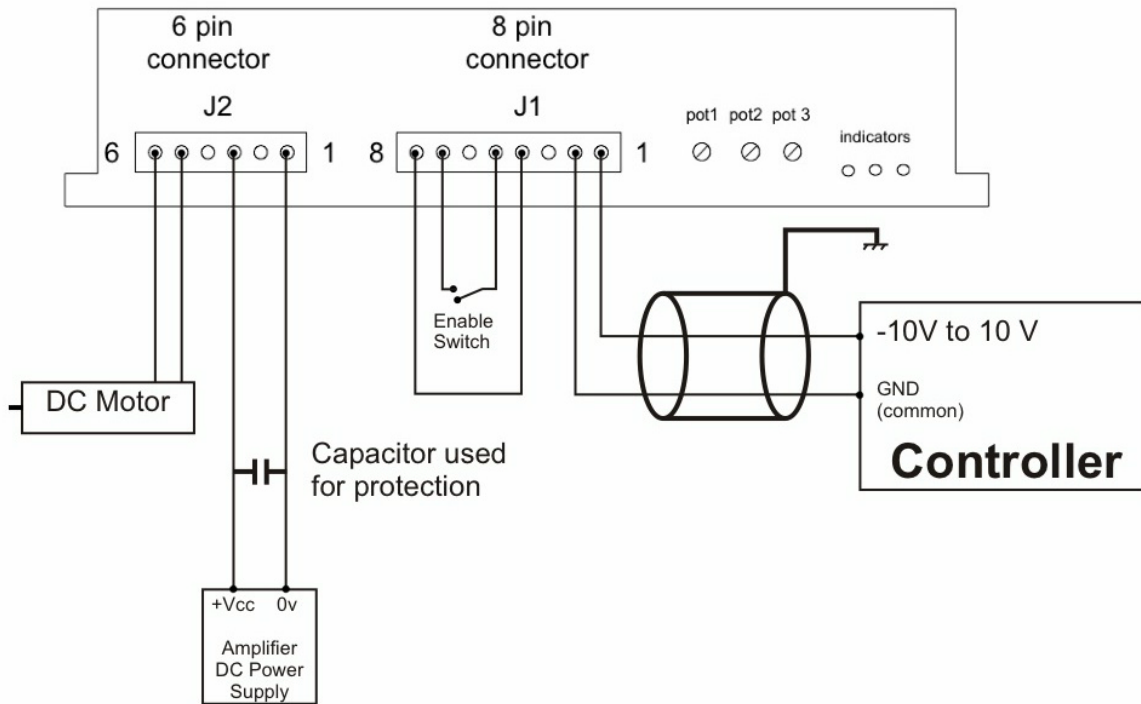

Enable Low

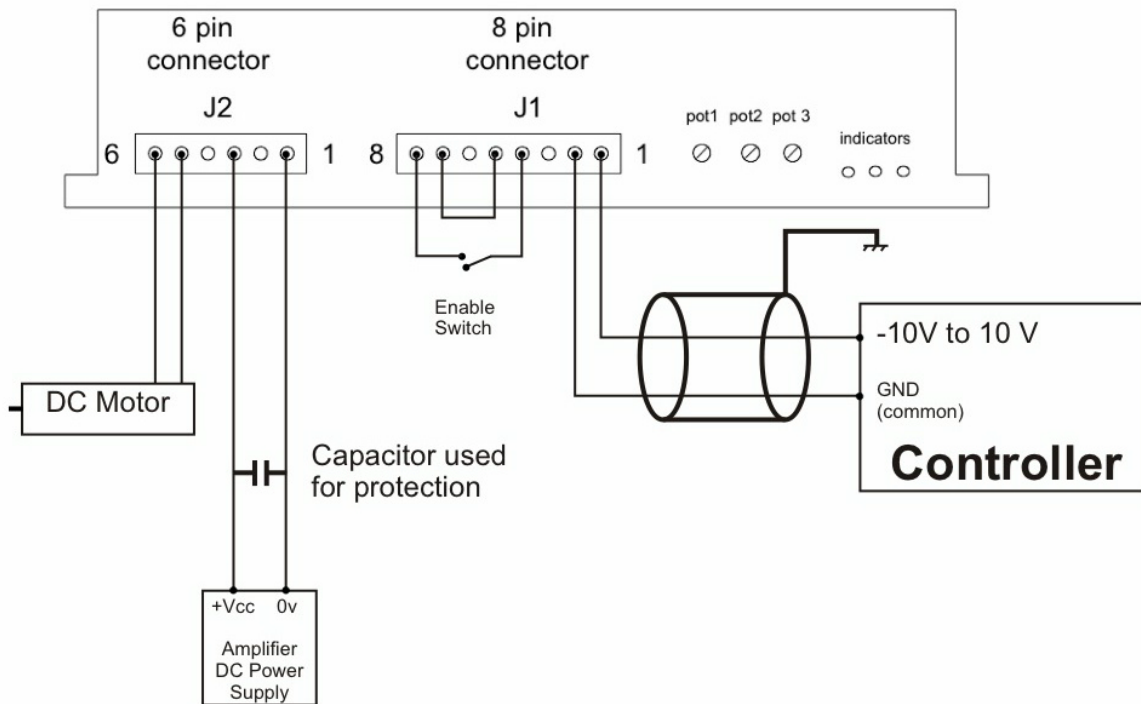

TRM International Ltd Ltd. 86 Moss Road, Southport, Lancashire. PR8 4JQ

Web: <http://www.trminternational.com> email: sales@trminternational.com

Telephone: +44 (0)1704 563777 Facsimile: +44 (0)1704 565219

Amplifier J1 connections when using the TRM professional Motion Controller PMC2C or PMC3

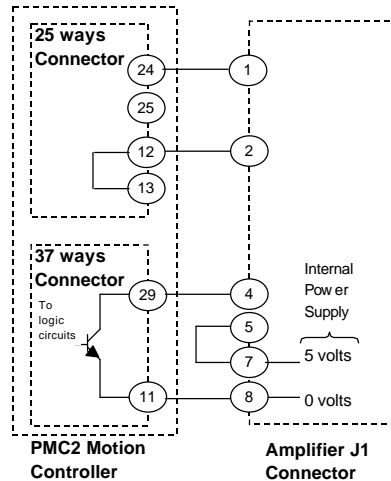

Fig. 3

CURRENT LIMIT ADJUSTMENTS

The Pot 3 'I' adjusts current limit. It has 24 active turns and it is approximately linear. Thus, to adjust the current limit, turn the potentiometer fully anticlockwise, then turn clockwise to the appropriate value. If the desired limit is, for example, 5 amperes, and the servo amplifier current is 10 amperes, turn the potentiometer 12 turns clockwise from the fully counter-clockwise position. When the Amplifier is limiting the current the LED with the 'I' label will turn ON in red showing the current has been limited.

OFFSET ADJUSTMENTS

Offset 'O' Pot 2 is used to adjust the amplifier for no motor movement. It is always useful when doing the installation to verify that when the analogue input signal is '0' volts the output is also '0' volts. If it is not then use this Potentiometer to move the offset until the desired value.

GAIN ADJUSTMENTS

Gain 'G' Pot 1 is used to adjust the ratio between input control signal and the output current. By default the gain is preset at TRM's factory at its maximum gain.

Mechanical specifications:

*All dimensions are in mm.

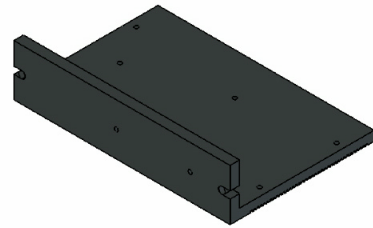
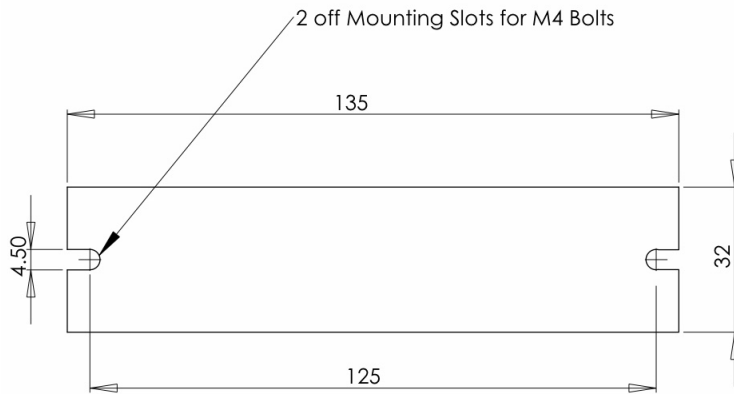

POWER CONNECTOR	Screw terminals
SIGNAL CONNECTOR	Screw terminals
SIZE	135 x 89 x 32 millimetres
WEIGHT	395 g
MOUNTING	4.5 mm slots

For further details, enquiries or help please contact us at:

TRM International Ltd.
86 Moss Road
Southport
Lancashire
PR8 4JQ
United Kingdom
TEL: +44 (0) 1704 563777
FAX: +44 (0) 1704 565219
email: sales@trminernational.com
Web: <http://www.trminernational.com>